

Blustyle
by COTTO D'ESTE

CHÂTEAU ROYAL
PIERRE NOBLE

Blustyle[®] | BELLA
PER
SEMPRE
by COTTO D'ESTE

CHÂTEAU ROYAL
PIERRE NOBLE





CHÂTEAU ROYAL

PIERRE NOBLE

La visite au château plongé dans le vert de la campagne française, puis une promenade dans les rues élégantes du village et un déjeuner au bistrot: autour de nous, passion pour les belles choses, histoires de traditions nobles, habitations soignées, parfums raffinés et enthousiasmes chromatiques modernes. Et un gardien rassurant de tout ceci: la pierre.

Château Royal parle de la pierre et de son adaptation innée aux époques et aux styles en maintenant sa noblesse classique intacte. Une collection au goût rustique et vieilli, proposée en deux tonalités modernes et originales et en deux finitions superficielles: Naturelle, rugueux et aux contours ébréchés typiques de la pierre brute et Lappata, plus raffinée et à la douceur typique de la pierre usée par le temps.

La très riche sélection de graphiques, structures et formats donnent aux surfaces dallées un effet absolument naturel où il est impossible de trouver deux pièces égales.



Blustyle
by COTTO D'ESTE

BELLA
PER
SEMPRE





The visit to the castle in the heart of the French countryside, then a walk through the elegant streets of the village and breakfast in the Bistro: all around us there is a passion for beautiful things, stories of noble traditions, well kept homes with refined fragrances and modern chromatic enthusiasm. And a reassuring custodian of it all: stone.

Château Royal speaks of stone and its innate ability to adapt to the times and styles while maintaining its classic nobility.

A rustic, vintage collection, available in two modern and original tones and two surface finishes: Naturale, rough and with chipped edges typical of rough stone and Lappata, more refined and with the softness typical of stone worn over time.

The rich selection of graphics, textures and sizes give an absolutely natural effect to floor surfaces where it is impossible to find two identical pieces.



FONTAINEBLEAU

Château Royal est un projet esthétique à pose modulaire conçu pour recréer la variété naturelle des anciens revêtements de sol en pierre de carrière. Il comprend quatre formats proportionnés et facilement associables entre eux avec des compositions très harmonieuses.

Château Royal is an aesthetic creation with modular laying designed to recreate the natural variety of ancient quarry stone floors. The collection consists of four proportionate sizes which are easily combined into compositions that create great harmony.



cm 60x60



cm 40x60

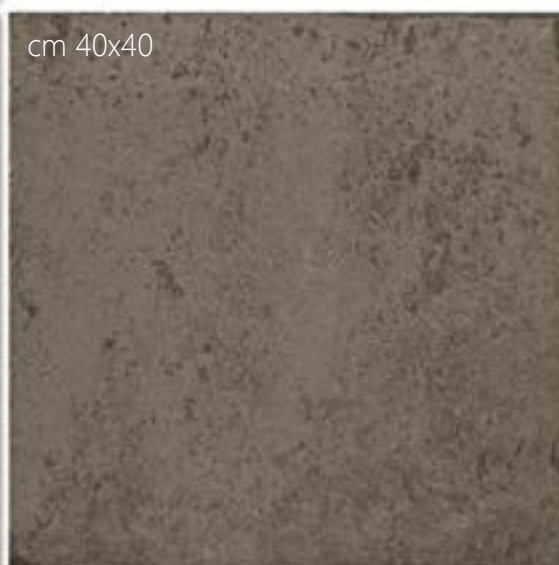

cm 40x40



cm 20x40



cm 60x60



cm 40x60



cm 40x40

AMBOISE

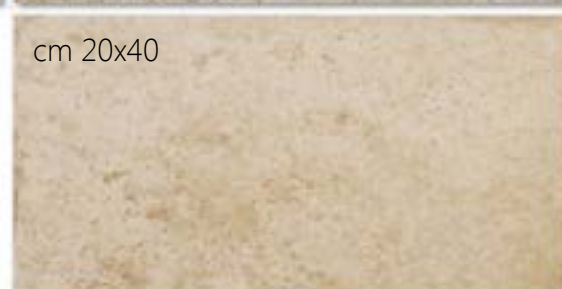

cm 20x40



A close-up photograph of a dark, textured stone tile. The tile has a rough, natural surface with subtle variations in tone and texture. A thin, polished edge of the tile is visible, showing a lighter, smoother finish. The lighting is soft, highlighting the texture of the stone.

LAPPATA
Rèctifie / Rectified

NATURALE



SURFACES







cm 40x40

cm 20x40

cm 40x60

cm 60x60

cm 40x40











AMBOISE LAPPATA RECT.
Module "B"





AMBOISE LAPPATA RECT.
Module "B"











cm 40x40

cm 20x40

cm 40x60

cm 60x60

cm 40x60







SCHÉMAS DE POSE LAYING SOLUTIONS

MODULE "A" "A" MODULE

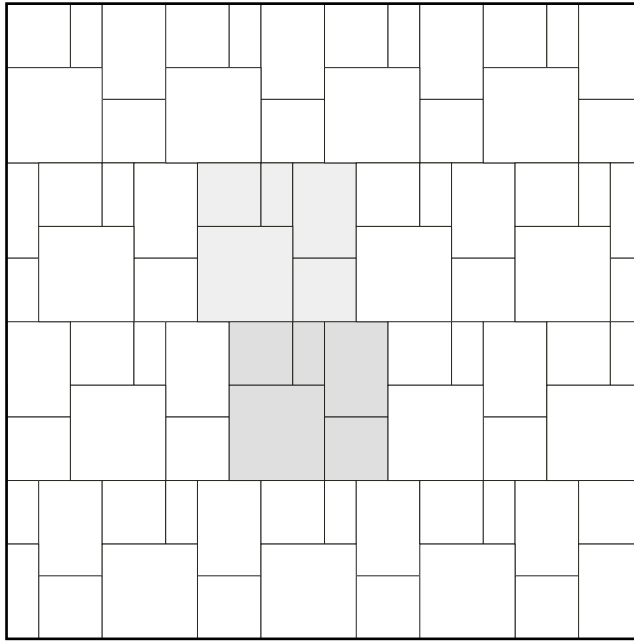

cm 60x60 (1 pièce/piece)	36,0%
cm 40x60 (1 pièce/piece)	24,0%
cm 40x40 (2 pièces/pieces)	32,0%
cm 20x40 (1 pièce/piece)	8,0%

MODULE "B" "B" MODULE

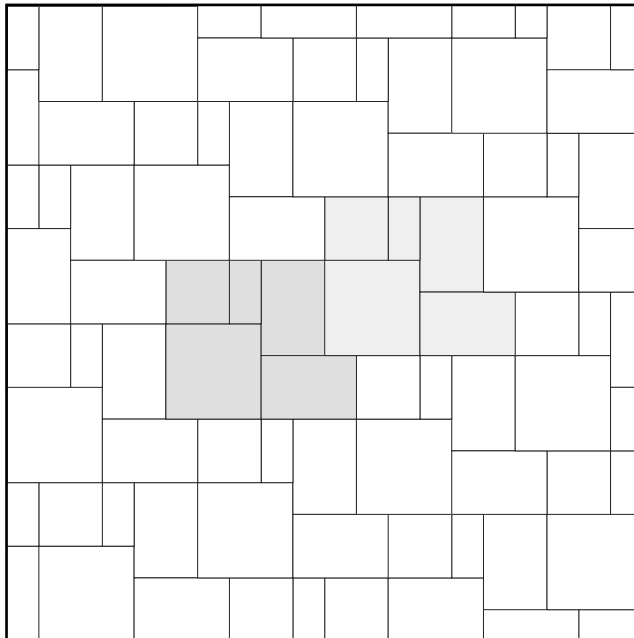

cm 60x60 (1 pièce/piece)	33,3%
cm 40x60 (2 pièces/pieces)	44,5%
cm 40x40 (1 pièce/piece)	14,8%
cm 20x40 (1 pièce/piece)	7,4%

TABLEAUX DES CALIBRES SIZE TABLES

FORMATS NATURELS NATURAL SIZES

60x60		40x60	
CALIBRE CALIBRE	W*(mm)	CALIBRE CALIBRE	W*(mm)
I	600,8x600,8	I	399,2x600,8
Q	603,2x603,2	Q	400,8x603,2
T	605,6x605,6	T	402,4x605,6
U	608,0x608,0	U	404,0x608,0
V	610,4x610,4	V	405,6x610,4

40x40		20x40	
CALIBRE CALIBRE	W*(mm)	CALIBRE CALIBRE	W*(mm)
I	399,2x399,2	I	197,6x399,2
Q	400,8x400,8	Q	198,4x400,8
T	402,4x402,4	T	199,2x402,4
U	404,0x404,0	U	200,0x404,0
V	405,6x405,6	V	200,8x405,6

Calibre "U" modulaire, posé avec joint de **4 mm***
Modular "U" calibrated, laid with a **4mm joint***

FORMATS POLIS ET RECTIFIÉS HONED AND RECTIFIED SIZES

60x60 RETT.		40x60 RETT.	
CALIBRE CALIBRE	W*(mm)	CALIBRE CALIBRE	W*(mm)
O	600,0x600,0	O	399,3x600,0
P	598,0x598,0	P	398,0x598,0
Q	596,0x596,0	Q	396,7x596,0
R	594,0x594,0	R	395,3x594,0

40x40 RETT.		20x40 RETT.	
CALIBRE CALIBRE	W*(mm)	CALIBRE CALIBRE	W*(mm)
O	399,3x399,3	O	198,7x399,3
P	398,0x398,0	P	198,0x398,0
Q	396,7x396,7	Q	197,3x396,7
R	395,3x395,3	R	196,7x395,3

Calibre "R" modulaire, posé avec joint de **2 mm***
Modular "R" calibrated, laid with a **2mm joint***

*Le poseur doit donc toujours contrôler le matériel avant la pose. Poser quelques carreaux (environ 3 m²) sur le sol sans les coller et en contrôler soigneusement les spécifications techniques et esthétiques générales.

The person in charge of installation must check all material before installing it. Place some tiles on the floor (approx. 3 m²) and check the overall technical and aesthetic characteristics with particular care.



CARACTÉRISTIQUES TECHNIQUES TECHNICAL FEATURES

RÉSISTANCE AU GLISSEMENT SLIPPERING RESISTANCE

DIN 51130	R11 NATURALE - R9 LAPPATA
DIN 51097	A+B NATURALE
BCR-TORTUS	μ > 0,40 NATURALE, LAPPATA
ANSI A137.1-BOT 3000	DCOF ≥ 0,42 NATURALE, LAPPATA
AS/NZS 4586 Wet pendulum test	P3 NATURALE
UNE ENV 12633 Pendulum	CLASE 2 NATURALE, LAPPATA
BS 7976-2 British pendulum test	PTV 36+Wet 4S (Slider 96) NATURALE

CHARGE DE RUPTURE (S) - Valeur moyenne BREAKING STRENGTH (S) - Average value

ISO 10545-4	≥ 220 kg (≥ 2150 N)
ASTM C 648	≥ 450 lbf

RÉSISTANCE À LA FLEXION - Valeur moyenne BENDING STRENGTH - Average value

ISO 10545-4	≥ 510 kg/cm² (≥ 50 N/mm²)
-------------	--

RÉSISTANCE À L'ABRASION PROFONDE DEEP ABRASION RESISTANCE

ISO 10545-6	≤ 145 mm³
-------------	-----------------------------

RÉSISTANCE AUX TACHES STAIN RESISTANCE

ISO 10545-14	CLASSE 5
--------------	-----------------

RÉSISTANCE À L'ATTAQUE CHIMIQUE RESISTANCE TO CHEMICAL ETCHING

ISO 10545-13	ULA-UHA <small>Non résistant à l'acide fluorhydrique et ses dérivés Not resistant to hydrofluoric acid and derivatives</small>
--------------	---

ABSORPTION D'EAU WATER ABSORPTION

ISO 10545-3	≤ 0,1%
-------------	---------------

RÉSISTANCE AU GEL FROST RESISTANCE

ISO 10545-12	INGELIVO - FROST PROOF
--------------	-------------------------------

DÉNUANCEMENT DESHADING

ANSI A137.1	V4
-------------	-----------

NETTOYABILITÉ / PULIBILITY

VISIBILITÉ DES EMPREINTES - Méthode Blustyle

Cette classification indique le degré de visibilité des empreintes laissées sur le sol après le passage avec des chaussures couvertes de poussière.

A - Empreinte non visible

B - Empreinte peu visible

C - Empreinte fort visible. Idéal pour le revêtement mur et proposé pour le revêtement sol uniquement dans des zones résidentielles.

TREAD MARK VISIBILITY - Blustyle method

This classification specifies the visibility degree of the tread marks left on the floor after walking with shoes dirty of dust.

A - Tread mark not visible

B - Tread mark not very visible.

C - Tread mark very visible. Ideal for wall installation and recommended for floor installation in residential areas only.

B NATURALE, LAPPATA

FACILITÉ D'ÉLIMINATION DE LA TACHE - Méthode Blustyle

La méthode consiste à classer le degré d'élimination de la tache de la saleté en général par un nettoyage manuel avec un produit léger.

Degré 1 - Très facile, aucune résistance à la saleté, nettoyage immédiat.

Degré 2 - Facile, légère résistance à la saleté, nettoyage rapide.

Degré 3 - Moins facile, une plus grande résistance à la saleté, nettoyage moins rapide. Il est conseillé d'utiliser un nettoyant fort. Idéal pour le revêtement mur et proposé pour le revêtement sol uniquement dans des zones résidentielles.

CLEANING EASINESS - Blustyle method

The method consists in classifying the easiness grade in removing general dirt by manual cleaning with mild detergent.

Grade 1 - Very easy, no resistance of the dirt, immediate removal.

Grade 2 - Easy, light resistance of the dirt, fast removal.

Grade 3 - Less easy, higher resistance of the dirt, slow removal. A strong detergent is recommended. Ideal for wall installation and recommended for floor installation in residential areas only.

2 NATURALE, LAPPATA

CERTIFICATIONS CERTIFICATIONS



EN 14411

Les DOP sont disponibles sur le site internet www.blustyle.it
DOP are available on the website www.blustyle.it



Certifications du système
qualité des sites productifs
Company quality control
certification for production sites



Certification du système
environnemental des sites productifs
Environmental certification
for production sites



EMAS
GESTIONE AMBIENTALE
VERIFICATA
reg. n. 1-000309

FINALE EMILIA (MO)
PRODUCTION SITE



EMAS
GESTIONE AMBIENTALE
VERIFICATA
reg. n. 1-000239

TOANO (RE)
PRODUCTION SITE



Blustyle, through Panariagroup Industrie Ceramiche S.p.A. holding, is a member of the U.S.Green Building Council and of the Italian Green Building Council.

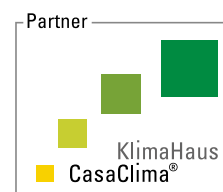

“  ”
Ceramics of Italy

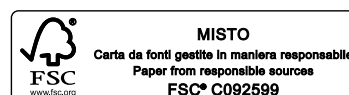

CHÂTEAU ROYAL

PIERRE NOBLE

GRÈS CÉRAMÉ / PORCELAIN STONEWARE

B1a UGL - MASSE COLORÉE/COLORED BODY - Décoration/Decoration: À JET D'ENCRE – EFFET 3D/INKJET – 3D EFFECT
Conforme/In compliance with: ISO 13006-G, EN 14411-G, ANSI A137.1

COULEURS / COLOURS



AMBOISE



FONTAINEBLEAU

ÉPAISSEUR / THICKNESS

10 mm

SURFACES ET FINITIONS / SURFACES AND FINISHING

NATURELE

LAPPATA ADOUCI, RECTIFIÉE ET PROFIL / HONED, RECTIFIED AND CHAMFER

FORMATS / SIZES

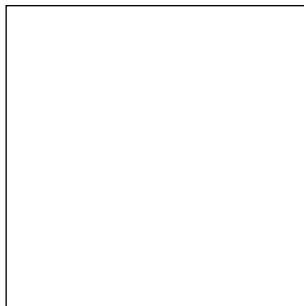

60X60 cm
24"x24"

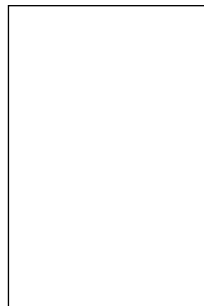

40X60 cm
16"x24"

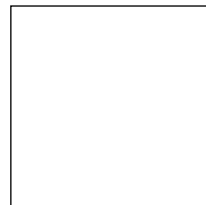

40X40 cm
16"x16"



20X40 cm
8"x16"

PIÈCES SPÉCIALES / SPECIAL PIECES

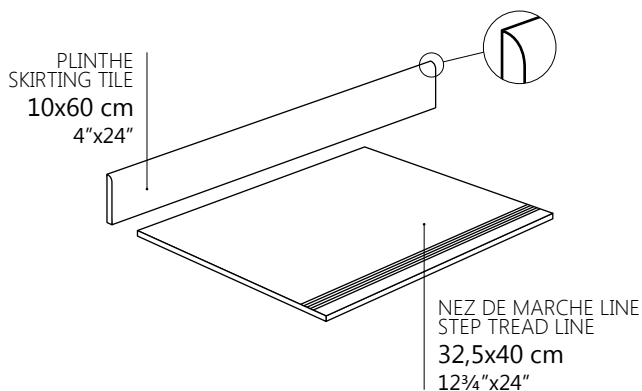

GARANTIE / WARRANTY



20 ANS RÉSIDENTIEL ET PUBLIC
20 YEARS RESIDENTIAL AND PUBLIC

Blustyle[®] | BELLA
PER
SEMPRE
by COTTO D'ESTE 

Blustyle[®] | BELLA
by COTTO D'ESTE | PER
SEMPRE

Via Emilia Romagna, 31 - 41049 Sassuolo (MO) Italy
ph. +39 0536 814911 - fax +39 0536 814921
blustyle.it - info@blustyleceramica.it

PANARIAGROUP INDUSTRIE CERAMICHE S.p.A.

